

Technical  
Drawing

Desenho  
Técnico

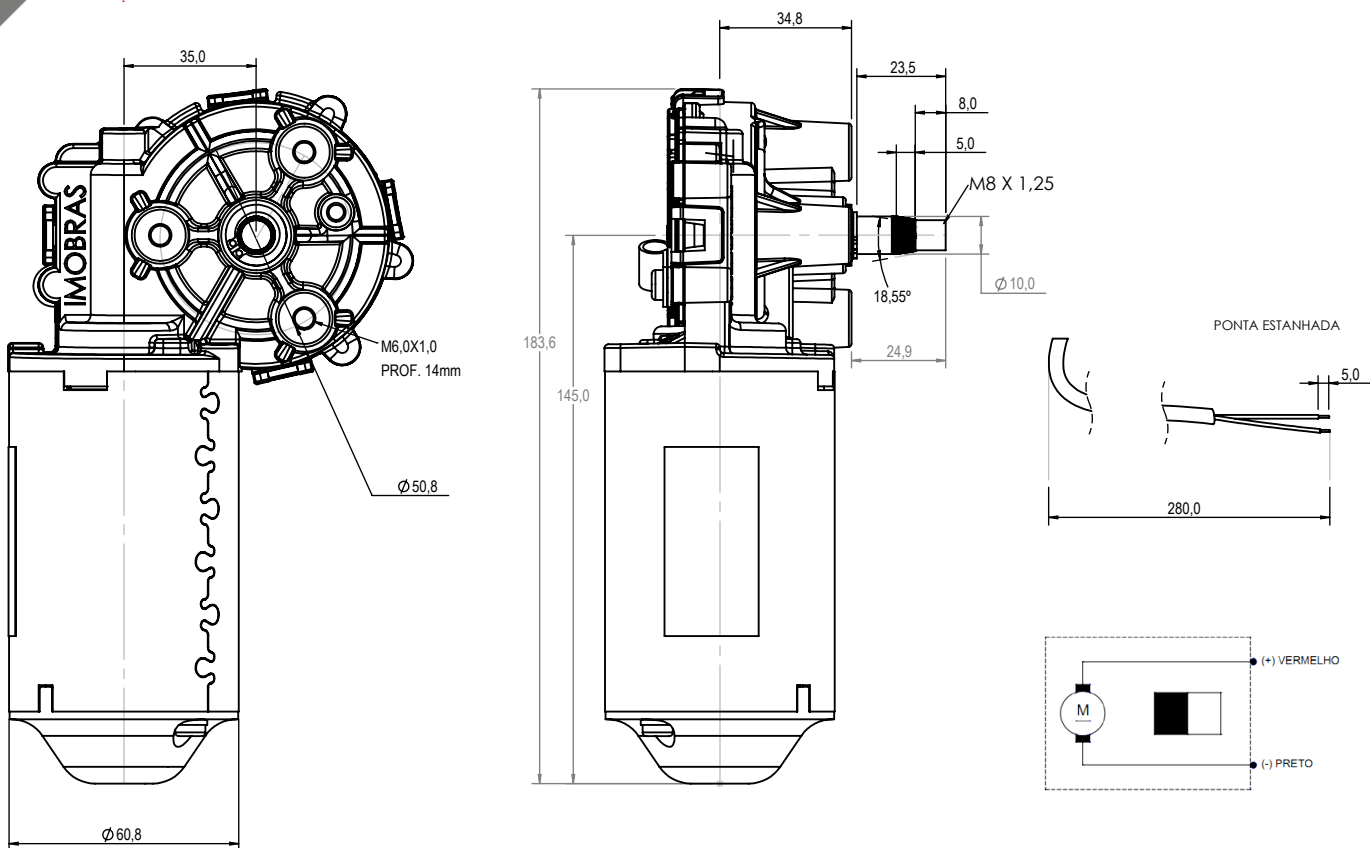

Technical  
Specification

Especificação  
Técnica

Imagem  
Ilustrativa

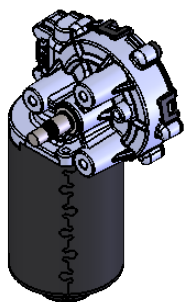

100400412

CARACTERÍSTICAS ELÉTRICAS	
U N (V)	13
P N (W)	20
n N (rpm)	29
I N (A)	4
I max (A)	19
M N (Nm)	6
M max (Nm)	30
I	63:1
Rotação	L / R
Peso (Kg)	1,500

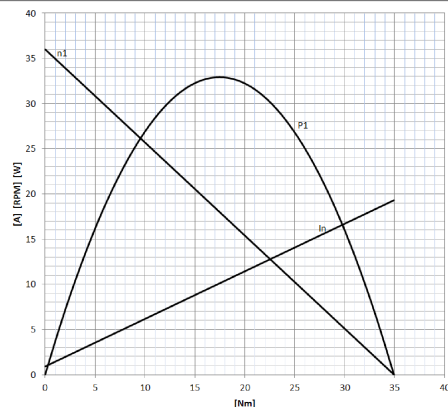

NOTAS

Aplicação: Industrial

Application: Industrial

100400424

CARACTERÍSTICAS ELÉTRICAS	
U N (V)	27
P N (W)	20
n N (rpm)	33
I N (A)	2,3
I max (A)	12
M N (Nm)	6
M max (Nm)	30
I	63:1
Rotação	L / R
Peso (Kg)	1,500

